

High Accurate Hall AC/DC Current Sensor CYHCS-LTHA

This Hall Effect current sensor is based on closed loop compensating principle and designed with a high galvanic isolation between primary conductor and secondary circuit. It can be used for measurement of DC and AC current, pulse currents etc. The output of the transducer reflects the real wave of the current carrying conductor.

Product Characteristics	Applications
<ul style="list-style-type: none"> • Excellent accuracy • Very good linearity • Small size and encapsulated • Less power consumption • Current overload capability 	<ul style="list-style-type: none"> • Photovoltaic equipment • General Purpose Inverters • AC/DC Variable Speed Drivers • Battery Supplied Applications • Uninterruptible Power Supplies (UPS) • Switched Mode Power Supplies

ELECTRICAL DATA

Part number	CYHCS-LTHA-100A	CYHCS-LTHA-200A	CYHCS-LTHA-300A		
Nominal current	100	200	300		A
Measuring range	300 (±18V, 80 Ω)	600(±18V, 20 Ω)	750 (±18V, 10Ω)	900 (±18V, 3Ω)	A
Turns ratio	1:2000	1:2000	1:2000	1:3000	
Measuring resistance	with±12V DC				
	@±100Amax 190(max)	@±200Amax 68(max)	@±300Amax 39 (max)	@±300Amax 56 (max)	Ω
	@±200Amax 80 (max)	@±500Amax 7.5(max)	@±500Amax 12(max)	@±600Amax 2(max)	Ω
	with±15V DC				
	@±100Amax 250(max)	@±200Amax 100(max)	@±300Amax 62(max)	@±300Amax 91(max)	Ω
	@±200Amax 110(max)	@±500Amax 20(max)	@±600Amax 15(max)	@±600Amax 15(max)	Ω
Nominal output current	50±0.2%	100±0.2%	150±0.2%	100±0.2%	mA
Secondary resistance	25	35	30	52	Ω
Supply voltage	±12 ~ ±18				V
Current consumption	20 + output current				mA
Galvanic isolation	50Hz, 1min, 6				KV

ACCURACY DYNAMIC PERFORMANCE

Zero offset current	±0.2	mA
Thermal drift of offset current	-40°C ~ +85°C, ±0.5	mA
Response time	<1.0	µs
Linearity	≤0.1	%FS
Bandwidth(-3dB)	DC... 150	kHz
di/dt following accuracy	>100	A/µs
Reference Standard	UL94-V0, EN60947-1:2004, IEC60950-1:2001, SJ 20790-2000	

GENERAL DATA

Operating temperature	-40 ~ +85	°C
Storage temperature	-40 ~ +125	°C
Unit weight	79	g

Dimensions (mm)

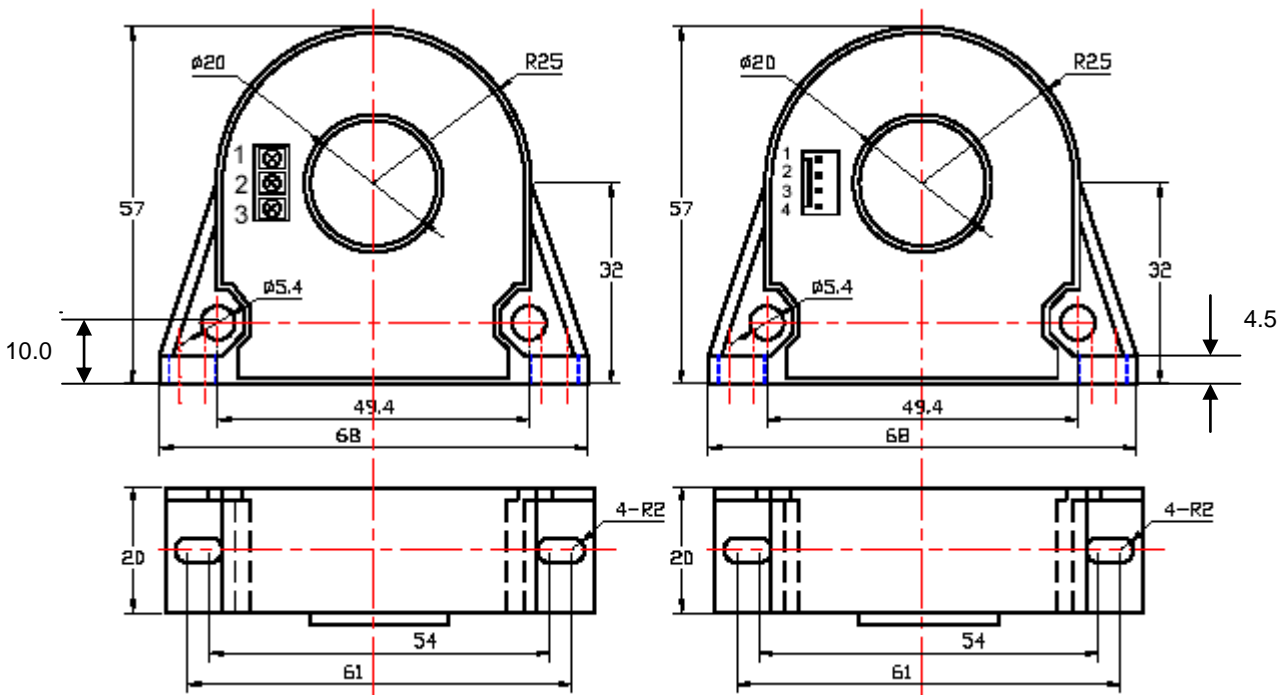

Screw Connection (P/N: CYHCS-LTHA2-xxxx)
DG300-5.0 Connector

Molex Connection (P/N: CYCS-LTHA1-xxxx)
Molex 22011042, 5045-04AG, 5051-04

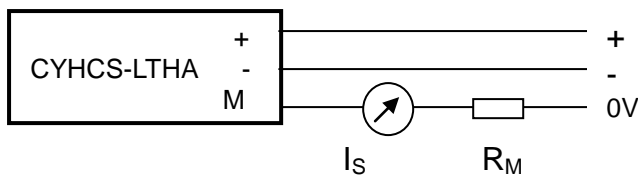

Pin & Terminal Arrangement

- 1(+): +15V
- 2(-): -15V
- 3(M): Output
- 4: NC

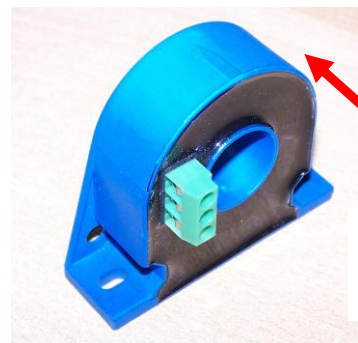

Current direction

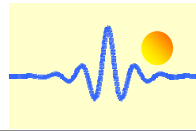

Characteristics chart

Response characteristics of a pulse current signal

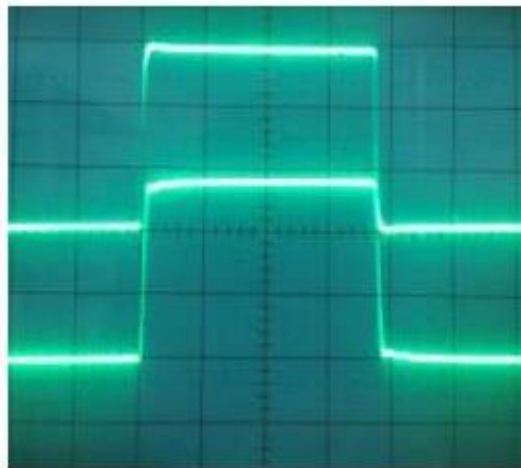

Input impulse current



Output Impulse voltage

Effect of impulse noise

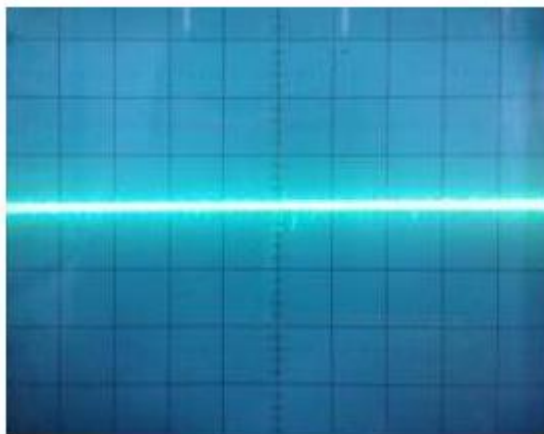

Output voltage

Operating instructions:

1. Connect the terminals of power source, output respectively and correctly, never make wrong connection for DC current.
2. Temperature of the primary conductor should not exceed 120 °C.
3. Dynamic performances (di/dt and the response time) are best with a single bar completely filling the primary hole.
4. In order to achieve the best magnetic coupling, the primary windings have to be wound over the top edge of the device.