

AC/DC Closed Loop Hall Current Sensor CYHCS-B2

This Hall Effect current sensor is based on closed loop compensating principle and can be used for measurement of DC and AC current, pulse currents etc. The output of the transducer reflects the real wave of the current carrying conductor.

Product Characteristics	Applications
<ul style="list-style-type: none"> • Excellent accuracy • Very good linearity • Small size and encapsulated • Less power consumption • Current overload capability 	<ul style="list-style-type: none"> • Photovoltaic equipment • General Purpose Inverters • AC/DC Variable Speed Drivers • Battery Supplied Applications • Uninterruptible Power Supplies (UPS) • Switched Mode Power Supplies • Motors etc.

ELECTRICAL CHARACTERISTIC

Nominal current	25	A
Measuring range	0 ~ ±50	A
Primary internal turn resistance	1.25	Ω
Nominal analogue output current I_s	25±0.5%	mA
Supply voltage	±15 (±5%)	V
Turns ratio	1-2-3-4-5:1000	
Galvanic isolation	50(60)Hz, 1min, 2500	V
Secondary internal resistance	110	Ω
Current consumption	10 + I_s	mA

ACCURACY DYNAMIC PERFORMANCE

Zero offset current at +25°C	±0.10	mA
Magnetic zero offset current (IP=0)	±0.15	mA
Thermal drift of offset current	±0.5 (-25°C~ +85°C)	mA
Accuracy (TA =25°C, VC=±15V)	±0.5	%
Linearity	≤ 0.2	%FS
di/dt accuracy followed	>50	A/μs
Response time	<1	μs
Bandwidth (-3dB)	DC ~ 150	kHz

GENERAL CHARACTERISTIC

Operating temperature	-25 ~ +85	°C
Storage temperature	-40 ~ +100	°C

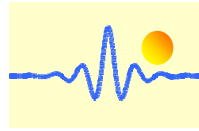

Dimensions (mm)

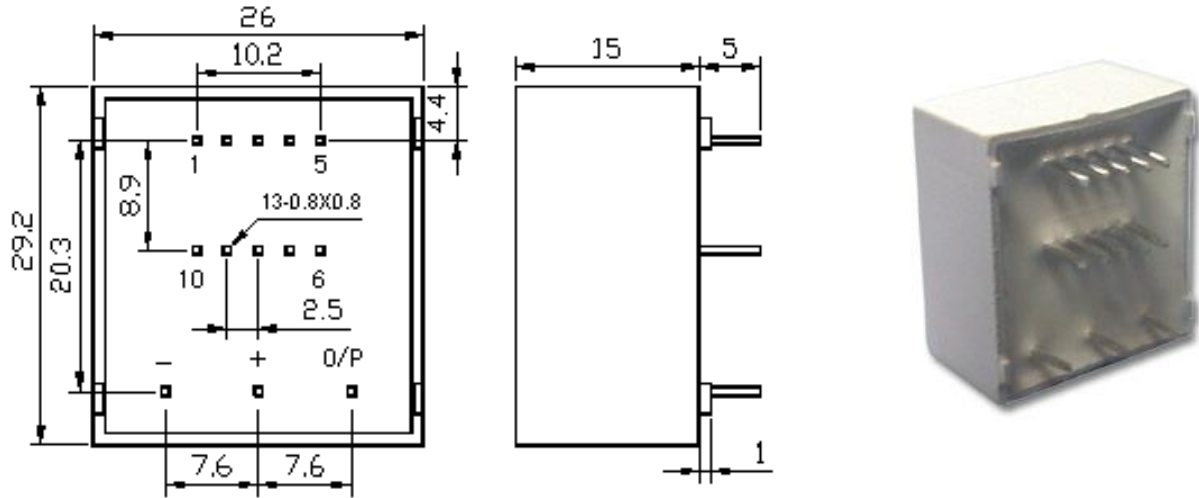

+ +15V
- -15V
O/P: Output

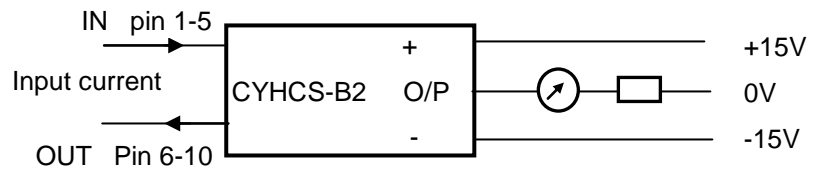

Wiring diagram

Primary Terminal	Nominal current (A)	Measuring range (A)	Output current (mA)	Pin connection
1	25	50	25	
2	12	24	24	
3	8	16	24	
4	6	12	24	
5	5	10	25	

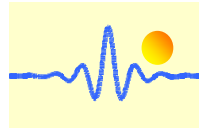

Primary Terminal	Nominal current (A)	Measuring range (A)	Output current (mA)	Turns ratio	Primary resistance (mΩ)	Primary leakage inductance (μH)
1	25	50	25	1/1000	0.3	0.023
2	12	24	24	2/1000	1.1	0.09
3	8	16	24	3/1000	2.5	0.21
4	6	12	24	4/1000	4.4	0.37
5	5	10	25	5/1000	6.3	0.58